

## Overview

Some digital systems have control bits that are set to HI or LO depending on the configuration of the system. A common example in a PC is a configuration jumper or dipswitch that sets which disc drive is the master or slave on an ISA bus. In other applications, these configuration bits may enable or disable a function such as a motor drive or lamp a during powerup to allow a processor time to take control of the system and enable functions in an orderly manner for safety or power budgeting reasons.

An unused nonvolatile digital variable potentiometer in a multiple potentiometer device can be used as a programmable configuration bit in these applications.

Such potentiometers as the [DS3903](#) or [DS1846](#) are examples of nonvolatile digital potentiometers that can be used in this manner. Each is a triple, NV digital potentiometer that can be used in an application such as power supply margining where only two potentiometers might used to adjust the voltage levels of a positive and negative supply. The spare potentiometer can be used as a programmable configuration bit to enable a particular power supply or other function on power up. This configuration could occur during the manufacturing process or during system level configuration with the potentiometer under microprocessor control.

The configuration is simple and given below. The potentiometer needs to be set to the high or low side of it adjustment range and be configured as shown below. Details on accomplishing these settings can be found in the data sheet for the specific device being used. While the DS3903 and DS1846 are given as examples, any NV digital potentiometer may be used in this manner. This concept may be expanded to include spare digital potentiometers in volatile potentiometers with the exception the configuration must occur after powerup and can be changed at will under the control of the host microprocessor.

**Figure 1. Example Potentiometer Setting Digital Configuration Bits**

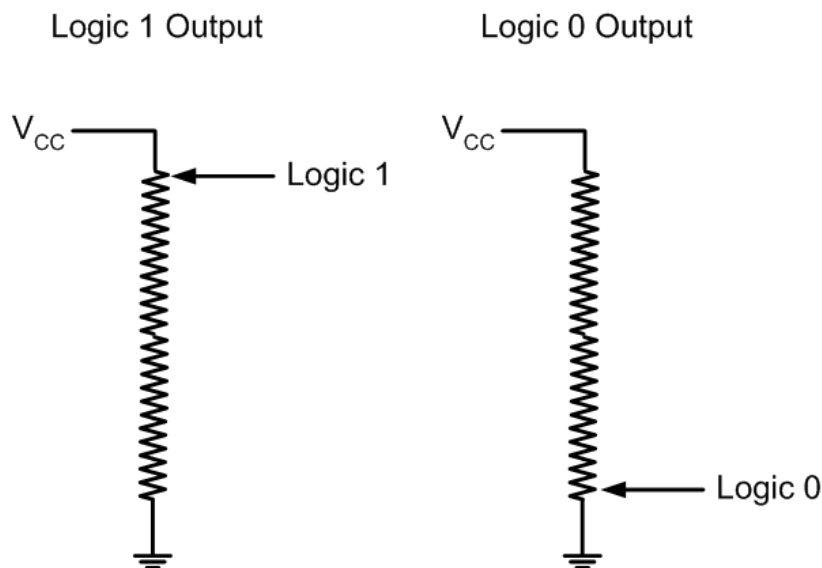

---

A link to a selection guide for all digital variable potentiometers from Dallas/Maxim is given below. This selection guide includes both volatile and NV variable potentiometers.

<http://www.maxim-ic.com/DigitalPotentiometers.cfm>

For a complete list of NV potentiometers available, a link to digital pots selection tables is given below. This selection guide includes both volatile and non-volatile potentiometers.

<http://www.maxim-ic.com/DigitalPotentiometers.cfm>

Other potentiometers are in development which have this configuration capability built in and can be used not only as a potentiometer, or configuration bit, but as a programmable transmission gate for both digital and analog signals. This simplifies the circuit designer's task by offering the flexibility of multiple capabilities in a single package. Contact the factory or the Maxim/Dallas website, [www.maxim-ic.com](http://www.maxim-ic.com), for these new product offerings.